

2809016022

Emergency Communication Wall Unit

1602 Wall Unit with Mass Notification

This product is only available in the Americas

Emergency points

Description

- ✓ Integrated emergency and wide-area emergency broadcast system
- ✓ Concealed high-power speakers provide 180° coverage
- ✓ Attention getting Blue LED light strobe included and mounted behind polycarbonate window: Blue light continuously lit, light activated by EMERGENCY button when call is placed or by a command of a remote guard calling into the emergency intercom.
- ✓ Radius front corners provide contemporary architectural styling
- ✓ Faceplate is continuously lit by ultra bright LED front panel
- ✓ Designed to resist extreme weather conditions
- ✓ A variety of lettering, signage and color choices are available
- ✓ Amplifier and speakers mount internally and are included with enclosure
- ✓ Station must be equipped with a PA interface adapter board to use internal PA amplifier and speakers
- ✓ Voltage Options - 120 VAC, 12/24 VDC & 24 VAC

The emergency/security wall unit is a high visibility, vandal resistant, stainless steel unit designed for use with the Zenitel Emergency/Security Stations. The Emergency/Security Wall Unit can be painted in blue, red and yellow as required.

The wall unit is ideal for use in parking facilities, college campuses, medical centers and multi-building complexes. The wall unit has an integrated blue light encased in Lexan. The blue light is always lit, calling attention to the location of the emergency communication unit. When the intercom station is activated, the light flashes at 78 fpm. The light flashes until either actively terminated by the personnel receiving the call

or automatically upon termination of the call itself.

The wall mount is equipped with a concealed LED panel light that continuously illuminates the face of the emergency phone. The wall mount is made of a vandal resistant, 12-gauge vertical brushed stainless steel, designed to withstand prolonged exposure to harsh environments.

The Turbine series of stations and the 1600TA Plate with TA-18USA backbox ([07216008140](#)) are both ordered separately. See more information on the specifications page for part numbers.

Technical Dimensions

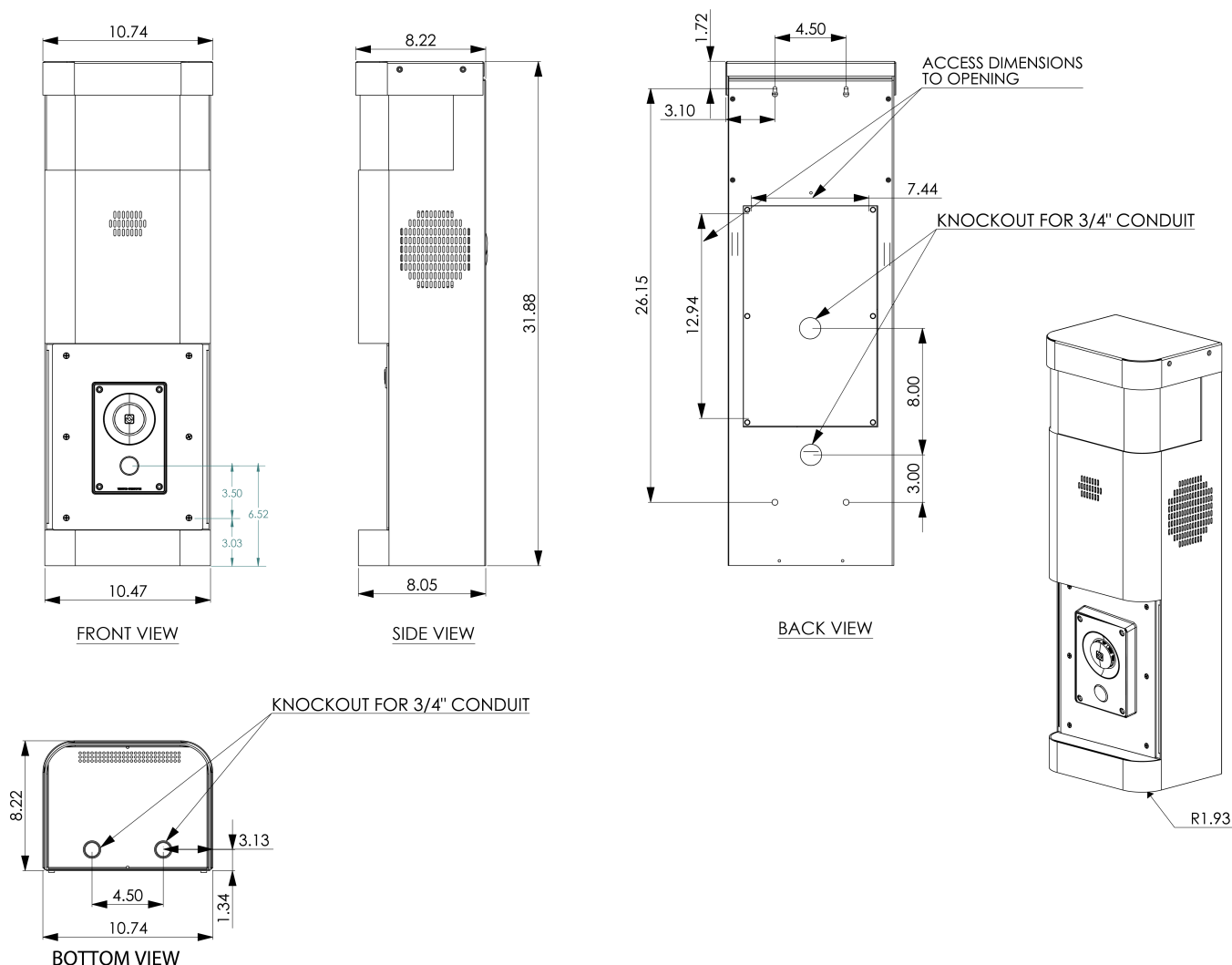

Specifications

GENERAL

Dimensions	10.74(273) W x 8.22(209) D x 31.88(810) H with 2.0(38) radius on front corners in (mm)
Mount Weight	50 lbs. (22.5 kg)
Construction	12-gauge stainless steel with impact resistant polycarbonate window
Broadcast Audio	Two 40-watt speakers with 33-watt amplifier
Lettering	Standard = "EMERGENCY". Lettering also available as "ASSISTANCE," "INFORMATION" or custom.
Mounting	Mounts to wall or straps to pole or kiosk. Contact Zenitel for necessary items for pole mounting.

Used With



[TCIS-2 | Audio Intercom](#)

IP and SIP Intercom



[Turbine Adapter Plate](#)