

3006202035

VMP-530VHM

Main Station In Waterproof Cabinet

 IP66

Description

- ✓ VMP-530VHM consist of main station VMP-530, with a waterproof, noise-compensated, handheld microphone P-66-VMP.
- ✓ Both items are interconnected and mounted inside a seawater-resistant cabinet
- ✓ Designed to be used together with ACM exchanges for wall mounting.
- ✓ To be used together with a separate loudspeaker
- ✓ Public Address messages via General Call and Group Calls
- ✓ Reception of Alarm signals with top priority
- ✓ Screw terminals for easy connection of installation cables and optionals

Technical Dimensions

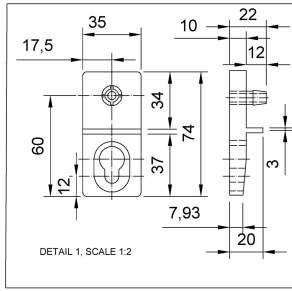

DOWN VIEW WITH DOOR CLOSED

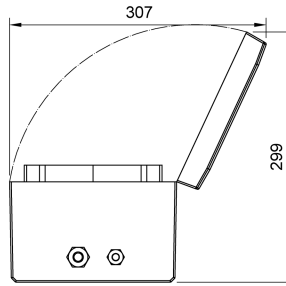
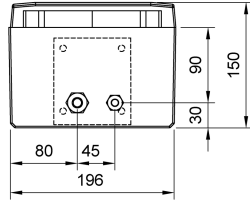

NOTES:

1- The cabinet to be mounted on the wall

FRONT WITH DOOR OPEN

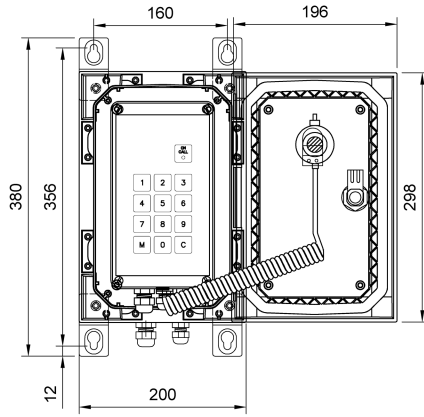

LEFT VIEW WITH DOOR CLOSED

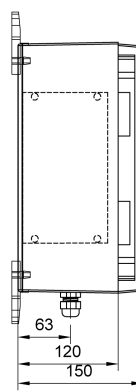

REAR VIEW WITH DOOR CLOSED

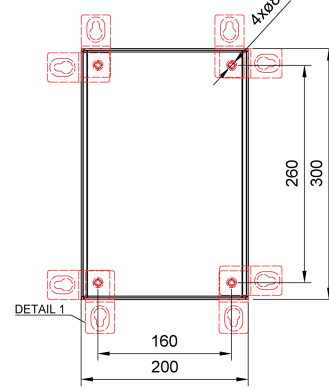

Specifications

SPECIFICATIONS

Operation voltage	Powered from exchange
Cable requirements	Twisted 2 pairs 0.5mm ² outer screen
Connections	Screw terminals
Loudspeaker Output	3.5 W (20 ohm)
Internal Loudspeaker impedance	50 ohm
Frequency range	500 - 5000 Hz
Material cabinet	Polycarbonate
Colour	RAL7035
IP- class	IP-66
Dimensions (mm)	300H x 200W x 152.5DT
Weight	4.5 kg
Specification VMP-530	See datasheet VMP-530 Doc.no. A100K 10531

Accessories



VML-1520

Horn Loudspeaker 15W, 20 OHM Waterproof