

1150100002

## ACM-M-D-V2 SYSTEM RACK

AlphaCom Marine Up To 6 Line Boards



- ✓ Tailored to meet marine specifications
- ✓ 1-BIT digital audio technology (18.5 kHz)
- ✓ Typed approved solution for two way communication, talkback, public address and general alarm for all types of vessels
- ✓ Extensive set of features for PABX and emergency communication
- ✓ Supports Vingtor-Stentofon integrated PA and GA solution
- ✓ Wide range of audio terminals and signal units
- ✓ External communication and billing
- ✓ Installation friendly with easy access to all terminals
- ✓ Remote management and supervision using IP and Web technologies
- ✓ Redundant power input with switchover



Onboard communication

### Description

The Vingtor-Stentofon ACM-M-D-V2 System rack AlphaCom Marine with up to 6 line boards is specially designed for use onboard ships. The system is based on the Vingtor-Stentofon AlphaCom exchange featuring the latest development such as IP telephony, Web management and IP switching. The Vingtor-Stentofon ACM Standard Integrated System supports the Vingtor-Stentofon integrated PA and GA solution. Together with the Vingtor-Stentofon SPA (Public Address), the system are extremely cost efficient where SPA loudspeaker loops are used together with the ACM intercom terminals to cover all areas requiring PA and GA onboard the ship.

The Vingtor-Stentofon ACM solution supports a wide range of conventional, IP and wireless communication terminals made for the offshore environment. The ACM intercom terminals are type approved as integrated PA, GA, telephone and talkback units. IP DECT base stations connect directly to the exchange over IP providing a very cost efficient solution to deploy a wireless network onboard. The DECT telephones, IP telephones and intercom terminals have all access to the same set of ACM features. Users will be able to enjoy the benefits of one user experience and seamless mobility as they will always be contactable regardless where they are on the ship. The ACM-M-D-V2 can be customized with a set of option packages. These include:

- ✓ Vingtor-Stentofon Billing system
- ✓ Analogue telephone gateway (4 or 8 channels)
- ✓ GSM telephone gateway
- ✓ IP DECT system
- ✓ Industrial data switch (4 ports)
- ✓ Public address zone switching
- ✓ Customized directory programming

The system is very service friendly. The exchange is mounted in a steel rack, providing easy access to all terminal blocks in the back side of the rack.

The system is type approved by DNV, RINA, CCS and CRS as an integrated communication system for two way communication, talk-back, Public Address (PA) and General Alarm (GA).

### Technical Dimensions

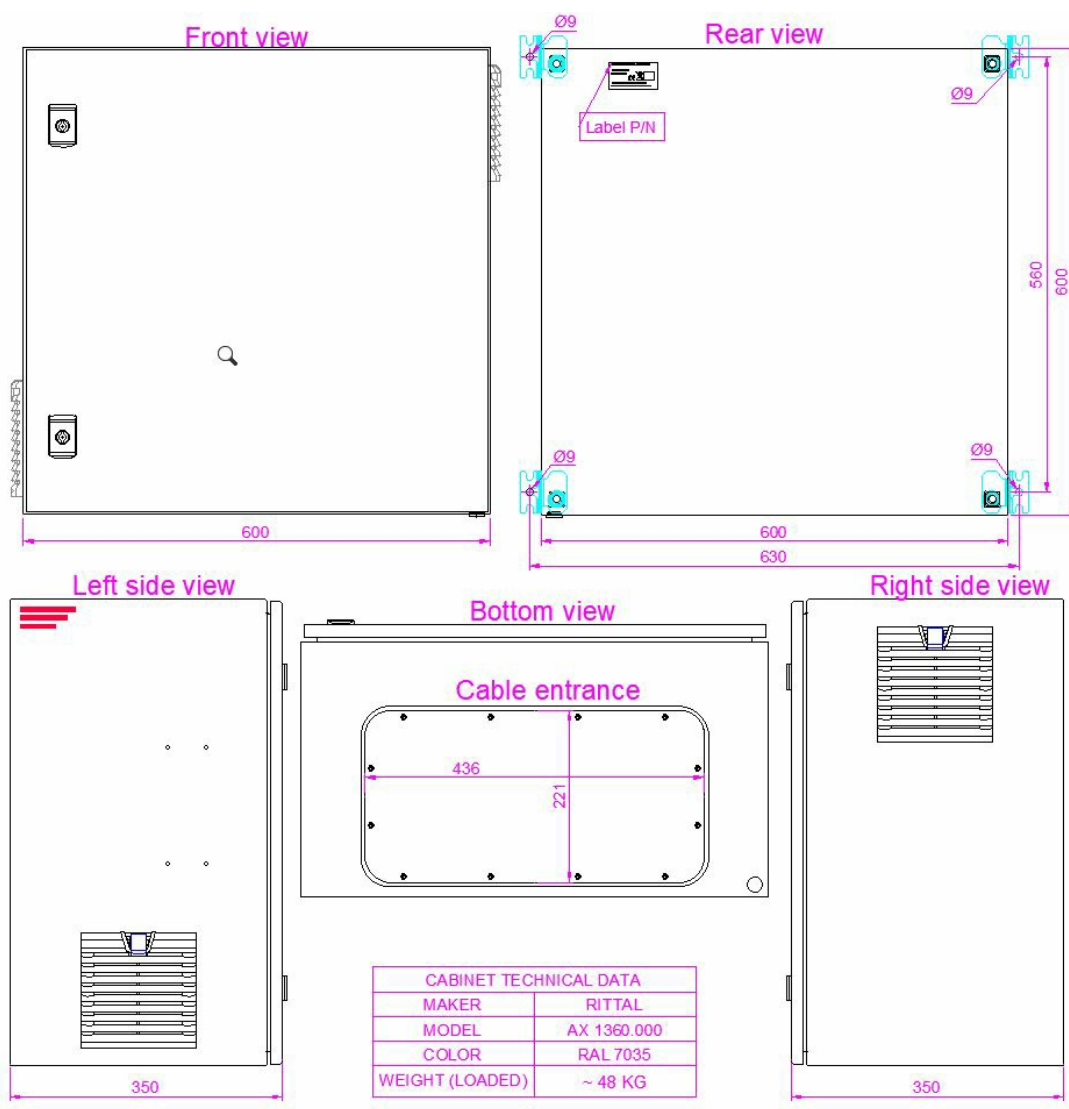

# Minimum clearance to sides 100mm for enabling ventilation

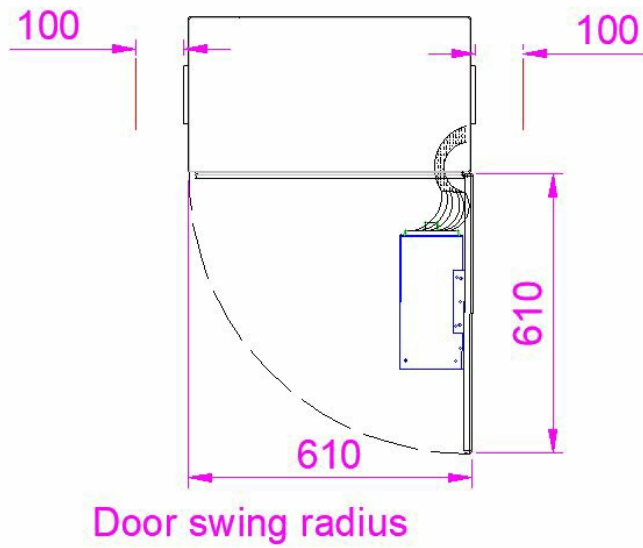

# Specifications

ORDER NUMBER	DESCRIPTION	SHIP WEIGHT
1150100002	ACM-M-D-V2 System rack AlphaCom Marine up to 6 line boards	45 kg
1153204050	Multi Relay Board with 6 Relays To extend the number of relays outputs	
Option for USA:		
2890010001	ACM-REL-110V 110V AC power option for ACM-M-D and ACM-M-A-V2	

## GENERAL

Dimension (WXHXD)	600 x 600 x 350 mm
Weight	45 kg
Mounting	Wall mounted
Temperature range	-15 - 55°C, recommended 18 - 25°C
Power	230V AC mains with auto switchover to 230V AC UPS or 24V DC emergency
IP class	IP 22
Subscriber capacity	Prewired for 6 subscriber line boards Max 36 traditional intercom Max 552 subscriber extensions
Integrated PA and GA interface	6 relay outputs (control signal) 6 inputs (control signal) 4 audio channels out 6 audio channels in PA zone selection require custom programming
Remote control	Option to add one relay card with 6 relay outputs
Audio technology	High resolution 1-Bit audio (18.5 kHz) – Wideband IP audio (8 kHz) – adaptive jitter buffers
External interface and billing	Option analogue telephone gateway Option GSM telephone gateway Option Vingtor-Stentofon Billing system
IP multi-module	Upto 4 ACM exchange racks
Data interfaces	2 x 10/100 Mbps Ethernet AutoMDIX (RJ45) 1 x RS232 serial data (RJ45)
Data networking	Option 4 port industrial data switch
IP protocols	IP unicast - IP multicast - IP v4 - TCP - UDP - Telnet - FTP – TFTP - NTP – HTTP - HTTPS - Syslog - SNMP v2c - SIP - RTP -RTCP - VoIP AlphaNet - Vingtor-Stentofon data – OPC
Remote system management	AlphaPro over IP Web