

1023253008

EBMDR-8

Exigo Button Expansion Module, 8 Buttons



- ✓ Button expansion module for ECPIR-x
- ✓ Powered from ECPIR-x
- ✓ Eight programmable buttons with individual labels and status indicators
- ✓ Optional button protection covers
- ✓ Four units can be connected to one access panel

EN54

EN 54 Certified



UL Certified Intercom



ICX-AlphaCom



Exigo

Description

The EBMDR-8 button expansion module is developed for expanding the button capacity of the ECPIR-x access panels or intercom. Each button features eight fully programmable buttons that can be used to manually initiate alarms, select zones, or any other action in the Exigo system.

Each of the module's buttons features two independent indicators that show the status of the button's function. Up to four EBMDR-8 button expansion modules can be daisy chained to one console panel.

Technical Dimensions

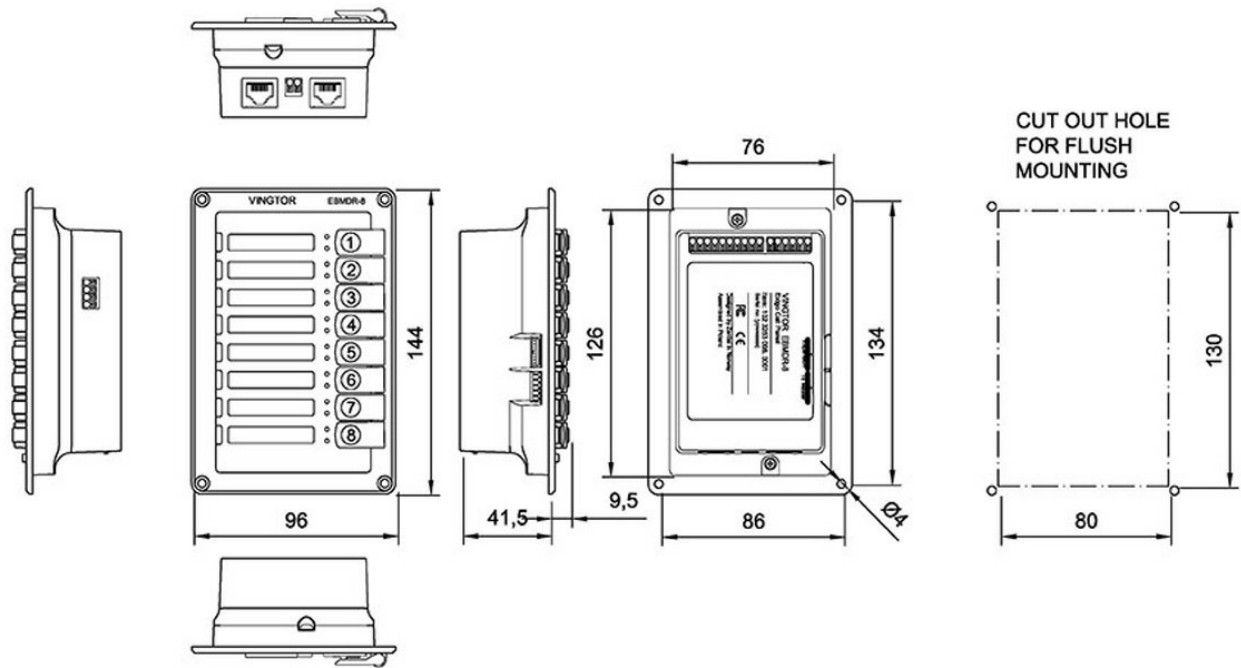

Specifications

MECHANICAL

Dimensions (HxWxD): 144 x 96 x 41.5 mm

Weight: 500 g

Storage temperature: -40°C to +70°C

Storage humidity: 10% to 95% (non-condensing)

Air pressure: 600 hPa to 1300 hPa

IP rating: IP-32

ENVIRONMENTAL

Operating temperature: -10°C to +60 °C

Operating humidity: 10% to 95% (non-condensing)

CERTIFICATIONS

Immunity: EN 60945, EN 50130-4, EN 61000-6-1, EN 61000-6-2, EN 55103-2, FCC-47 part 15B

Emissions: EN 60945, EN 50130-4, EN 61000-6-3, EN 61000-6-4, EN 55103-1, FCC-47 part 15B

Safety: UL 60950-1, cUL 60950-1, CB to IEC 60950-1

Accessories



EMBR-1

Mounting Box for ECPIR, EAPIR and EBMDR-8 Panels

EMBR-2

Mounting Box for ECPIR, EAPIR and EBMDR-8 Panels

Used With



ECPIR-3P

Exigo Access Panel / Turbine Intercom



ECPIR-P

Exigo Call Panel, PTT Button



EAPIR-8

EXIGO Alarm Panel, 8 buttons