

1023102200

## ENA2200

Exigo Network Amplifier 2 x 200W

SPARE PART ONLY. Replaced by 1023102210 ENA2200-AC2



EN54

EN 54 Certified



UL Certified Intercom



ICX-AlphaCom



Exigo

## Description

- ✓ 2x 200 watt continuous effect
- ✓ Power efficient class D technology
- ✓ 110-230 VAC primary power and 24-48 VDC secondary power
- ✓ Redundant Ethernet connections
- ✓ Digital audio processing, equalizer and audio delay
- ✓ Loudspeaker line monitoring
- ✓ Input for backup amplifier
- ✓ Tick tone generator
- ✓ 6 configurable control outputs
- ✓ 6 configurable control inputs

The Exigo Network Amplifier is designed for use in marine, offshore and other demanding environments. The amplifier utilizes state-of-the-art class D amplifier technology to ensure high power efficiency and superb audio quality.

The Exigo Network Amplifier is part of the Exigo PA/GA system, which is based on standard Ethernet network and digital processing. Each amplifier has two network connections, allowing for redundant cabling between the amplifier and the network. Using standard network equipment also allows for a much wider selection of standard network equipment.

The digital audio processing and maintenance of the amplifier is done with the embedded CPU and DSP. These components allow the amplifier to do advanced audio processing such as automatic gain control and equalizing while also maintaining a robust connection to the system controllers.

The complete amplifier is self-monitoring and this includes advanced monitoring of the speaker lines and internal system. The audio output channels can be monitored for line faults such as shorts, ground faults and large load changes. In addition, up to 10 intelligent Line End Transponders (ELTSI) can be placed on the speaker lines for additional accuracy in the line monitoring. The amplifier also monitors control inputs, power supplies, temperature, network connections and every other components required for operation of essential services. Faults will be reported to the system controller, but will also be indicated locally on the amplifier.

The amplifier operates from a primary 115/230 VAC supply and have automatic uninterrupted switchover to a secondary 24-48 VDC supply if the primary should fail. The amplifier will continue to operate with full service during and after the switchover.

The amplifier's configurable control inputs/outputs and audio inputs can be used locally by the amplifier (e.g. for PTT and audio from a handheld microphone) or can be controlled by the system (e.g. audio input for background music).

## Technical Dimensions

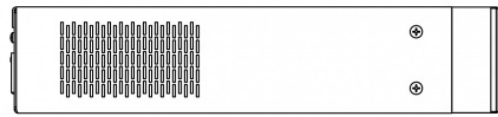
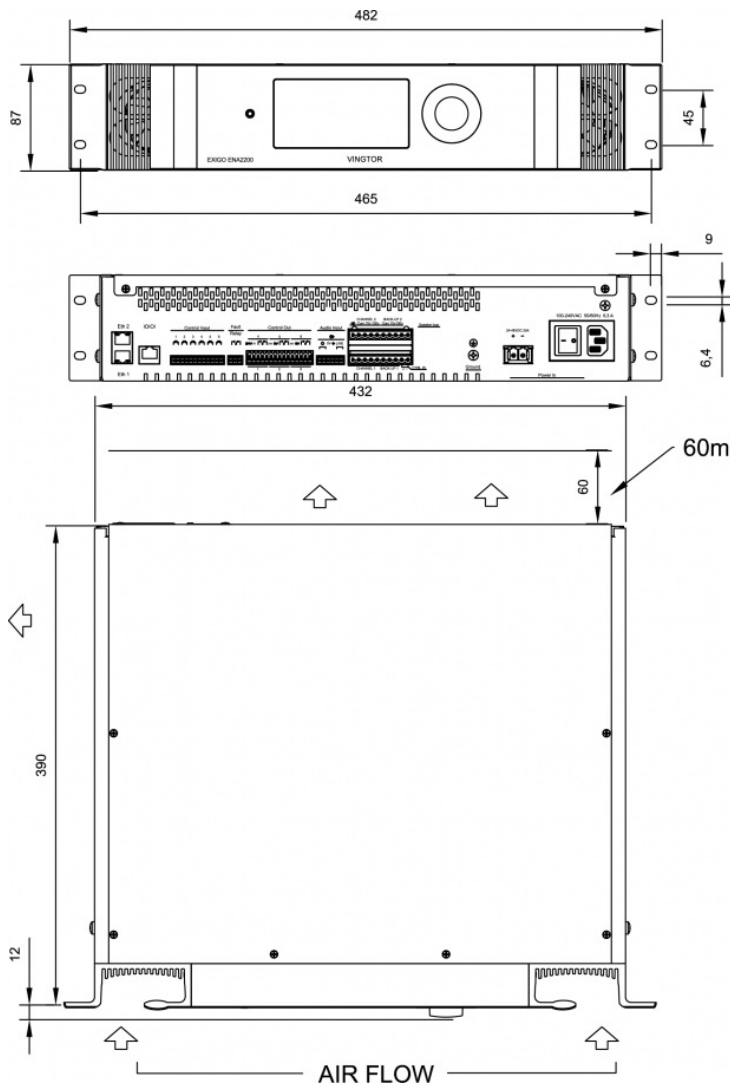

Weight 14.5 kg  
 IP-32  
 Powder coated, fine structure, Black RAL 9011  
 Aluminium extruded front and handles -  
 brushed surface, black anodized

SCALE 1:4 @ A3

# Specifications

## MECHANICAL

Dimensions (HxWxD)	87 x 482 x 390 mm
Weight	13 kg
Shipping Weight	14.5 kg
Mounting	19" Rack, 2HU
Color	Black

## USER INTERFACE

Display	3.5" QVGA Color TFT LCD
Button	Rotary selector button with push-to-select
Indicators	Primary power, Secondary power, Fault, Disabled

## ENVIRONMENTAL

Operating temperature	-15 °C to +55 °C
Operating humidity	15% to 95% (non- condensing)
Storage temperature	-40°C to +70°C
Storage humidity	10% to 95% (non- condensing)
Air pressure	700 hPa to 1300 hPa
IP rating	IP-32

## ELECTRICAL

---

### Primary power

---

Connector	V-lock, IEC 60320-1 C14 compliant
Nominal voltage * **	110 – 230 VAC, 47-63 Hz
Inrush current	Max 16A
Power consumption	$P_{nom} \leq 25 \text{ W}$ (idle), $P_{max} = 650 \text{ W}$

---

### Secondary power

---

Connector	Pluggable and lockable terminal
Nominal voltage *	$V_{nom} 24 - 48 \text{ VDC}$ , $V_{min} 20 \text{ VDC}$ , $V_{max} 63 \text{ VDC}$
Power consumption	$P_{nom} \leq 25 \text{ W}$ (idle), $P_{max} = 650 \text{ W}$
	* Degradation to 2 x 120W on 110Vac and 24Vdc
	** Power cord not included

---

## AUDIO OUTPUTS

Output power	2 x 200 watt music @ 55 °C continuously, 2 x 200 watt alarm @ 40°C continuously, 2 x 200W alarm @ 55°C 30min
Output power in degradation mode (Running on 110Vac or 24Vdc)	2 x 120 watt music @ 55 °C continuously, 2 x 120 watt alarm @ 40°C continuously, 2 x 120W alarm @ 55°C 30min
25V (8 ohm) output	2 x 50 watt music @ 55 °C continuously, 2 x 50 watt alarm @ 50 °C continuously,
Output line	100 volt, 70 volt and 8 Ohm
Frequency response	200 Hz to 20 kHz $\pm$ 3 dB
Audio codec	G711, G722, PCM L16/48kHz
SNR	86 dB in test-modus, A-weighted noise
THD	< 0.5% @ 1 kHz
Rated load resistance	100V: 50 $\Omega$ , 70V: 25 $\Omega$ , 25V: 25.0 $\Omega$
Rated load capacitance	470 nF

## NETWORK

---

Ethernet	2 x 10BASE-T, 100BASE-TX, Auto negotiation, Auto MDIX
----------	---

---

Protocols	Protocols IPv4 (with DiffServ), TCP, UDP, HTTPS, TFTP, RTP, DHCP, SNMP, STENTOFON CCoIP®, NTP
-----------	---

---

LAN Protocols	VLAN(IEEE 802.1pq), Network Access Control (IEEE 802.1x), STP (IEEE 802.1d)
---------------	---

---

Management and operation	HTTP/HTTPS (Web configuration) DHCP and static IP Remote automatic software upgrade Centralized monitoring
--------------------------	--

---

## LINE INPUT

---

Frequency response	80 Hz – 20 kHz
--------------------	----------------

---

Audio codec	G711, G722, PCM L16/48kHz
-------------	---------------------------

---

Nominal input level	100 mVRMS – 1 VRMS
---------------------	--------------------

---

SNR	80 dB
-----	-------

---

Input impedance	600 $\Omega$ / 10 k $\Omega$ (selectable)
-----------------	---

---

## MICROPHONE INPUT

Frequency response	80 Hz – 20 kHz
Audio codec	G711, G722, PCM L16/48kHz
Nominal input level	1 mVRMS – 100 mVRMS
SNR	80 dB
CMRR	45 dB
Input impedance	600 $\Omega$ / 10 k $\Omega$ (selectable)
Phantom supply (optional)	12 VDC $\pm$ 10% @ 15 mA (IEC 61938, P12)

## CONTROL INPUTS AND CONTROL OUTPUTS

Control Inputs	6
Type	Closing contact, monitored
Control Outputs	6
Relay outputs: (COM, NO,NC)	Max recommended levels: 3A, 100Vdc, 125Vac, switching 60W/125VA
24 V outputs	24 VDC $\pm$ 10%, 200 mA, monitored
Fault relay	1
Relay outputs: (COM, NO,NC)	Max recommended levels: 3A, 100Vdc, 125Vac, switching 60W/125VA



## CERTIFICATIONS

Immunity	EN 60945, EN 50130-4, EN 61000-6-2*, EN 55103-2
Emissions	EN 60945, EN 61000-6- 4*
Safety	EN 60065, EN 60950, IEC 60529

\*When used in  
conjunction with PN:  
1023598000 &  
1023598100

## Accessories



### EAM-200

ENA2200 Amplifier Module



### EPMA400

ENA2200 Amplifier Power  
Supply



### ELTSI-1

Exigo Industrial Line End  
Transponder