

4000017576

P-9016

Substation for Speaker



- ✓ Built-in call relay, maximum 8A
- ✓ Call lamp
- ✓ Plug for connection of headset or handheld microphone
- ✓ CALL button
- ✓ Selector switch for headset or loudspeaker operation
- ✓ Complies with IEC 60945 Standard for Marine Equipment
- ✓ RMRS type approval



Onboard communication

Description

The P-9016 is a weatherproof command intercom system (talk-back) substation for industrial and noisy environments such as engine, steering gear and thruster rooms. It interfaces an external loudspeaker, external call signal device (flash/rotating light/hooter/siren) and a pluggable hearing protective headset.

The unit is equipped with a loudspeaker/headset selector toggle switch, a CALL button for attention request and a call lamp for visual call indication.

Technical Dimensions

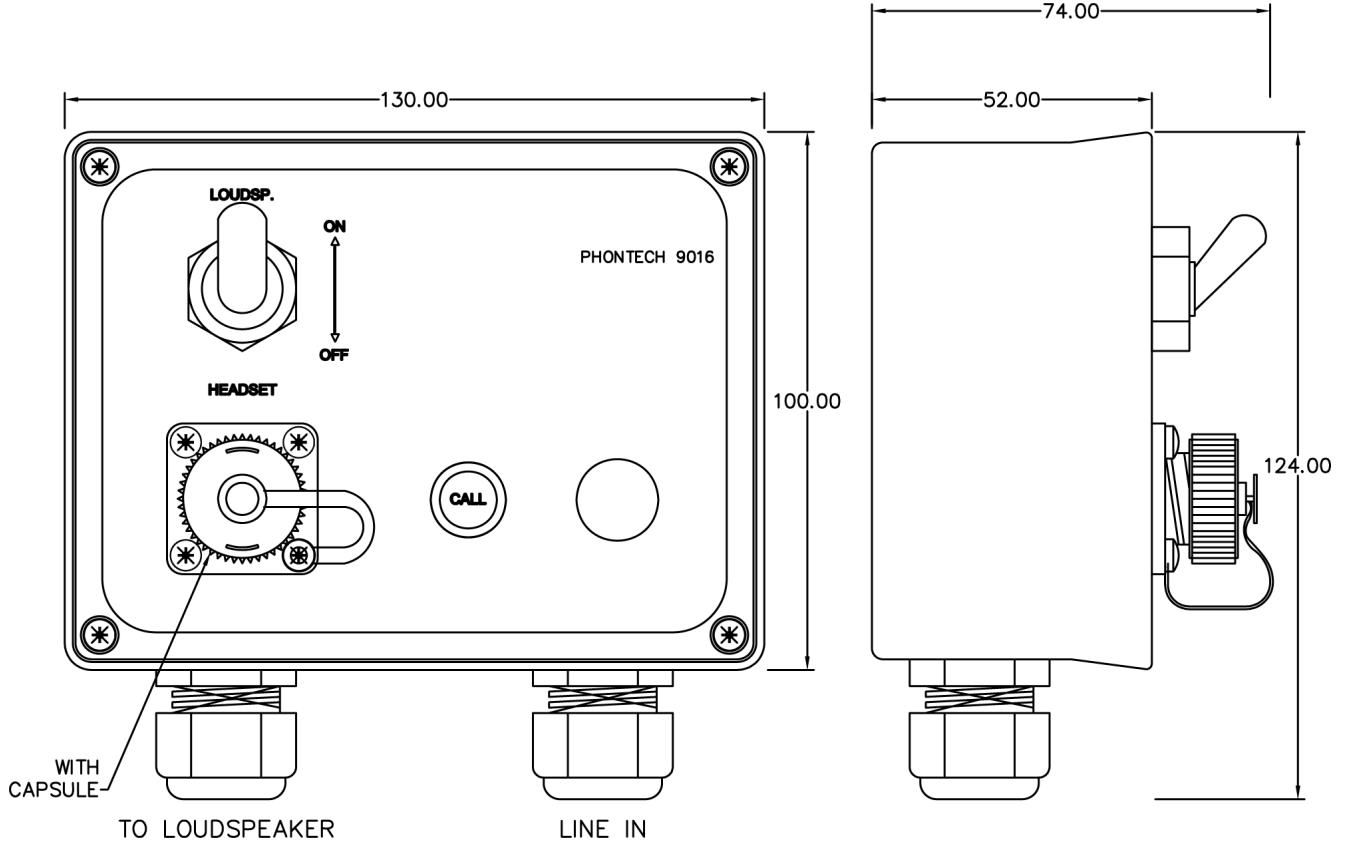

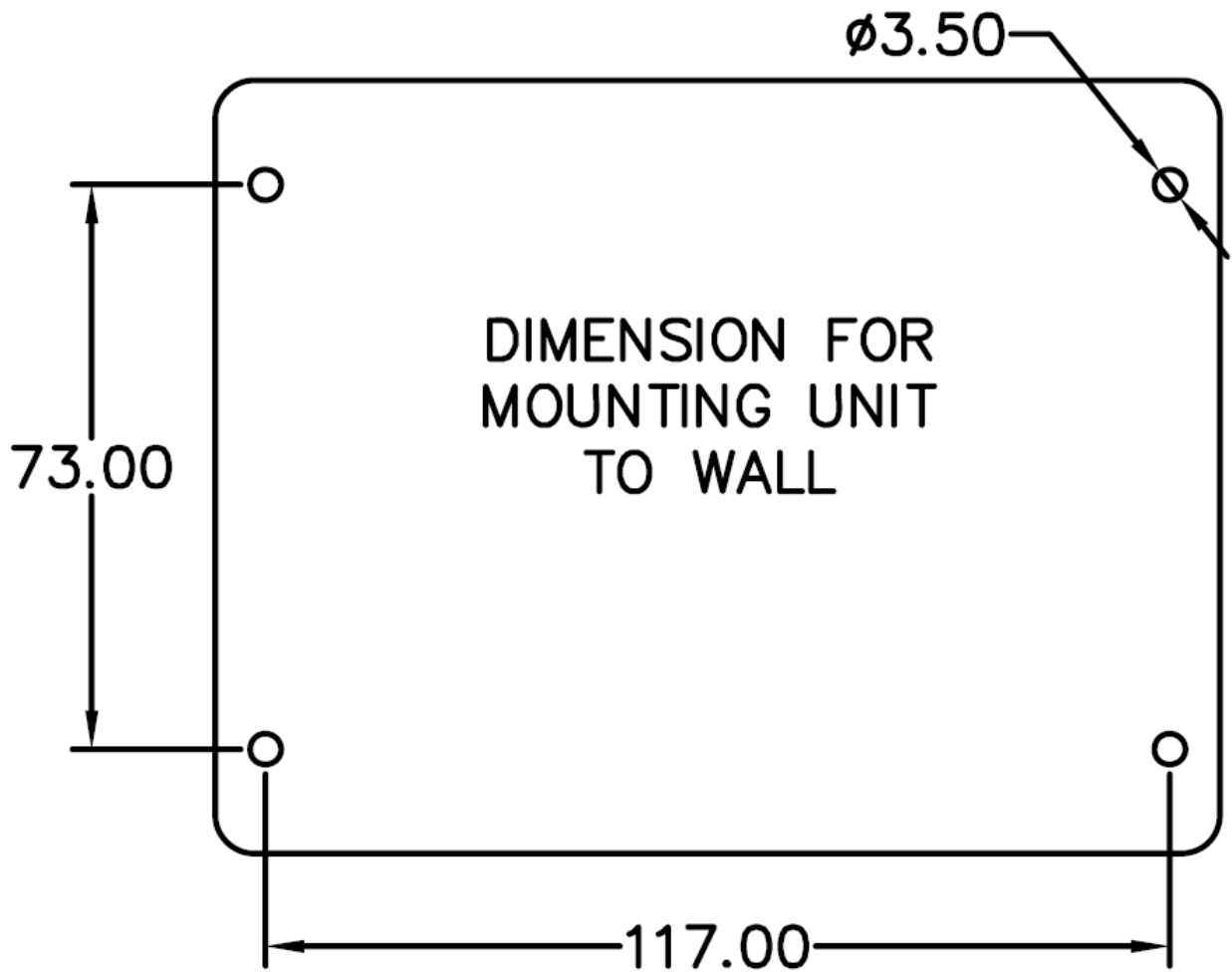

Specifications

MECHANICAL

Dimensions (WxHxD)	130x124x52 mm (depth 74 mm including toggle switch)
Weight	0.3 kg
Color	RAL 9005/9006
Material	PC/ABS blend, ABS
Mounting	Wall
Fixing	4 x M3 bolts
Access	Front
Cable Entry	Bottom/Top
Gland Type	2 x M20

ELECTRICAL

Power Supply	(24 VDC) From central/line supply
Switching current	8A
Termination	Screw terminals ≤ 1.5 mm ²
Compass Safe Distance	> 5 m

ENVIRONMENTAL

Temperature	-25°C to +55°C (Storage: -25°C to +70°C)
Humidity	+93% (at +40°C)
Ingress Protection Rating	IP-44

