

1020600771

## VSP-36-PEL-A

Headset with boom mic, headband, and 10m cable



- ✓ Headset for connecting directly to a VSP station
- ✓ ON / OFF switchbox w/ belt clip
- ✓ Excellent noise performance
- ✓ High attenuating ear shells
- ✓ Standard with 10 meter cable



IP54



Onboard communication

## Description

The VSP-36-PEL-A headset brings hearing protection and communication in noisy environments into a new level of performance with newly designed speakers and microphone.

The dual cup give a modern and slim look and is specially designed to provide excellent noise attenuation.

## Applications

The VSP-36-PEL-A headset can enhance communication in noisy environments and other workplaces, where the workers need to be connected to their 2-way handheld or fixed systems throughout the day to help facilitate frequent contacts with co-workers.

## Technical Dimensions

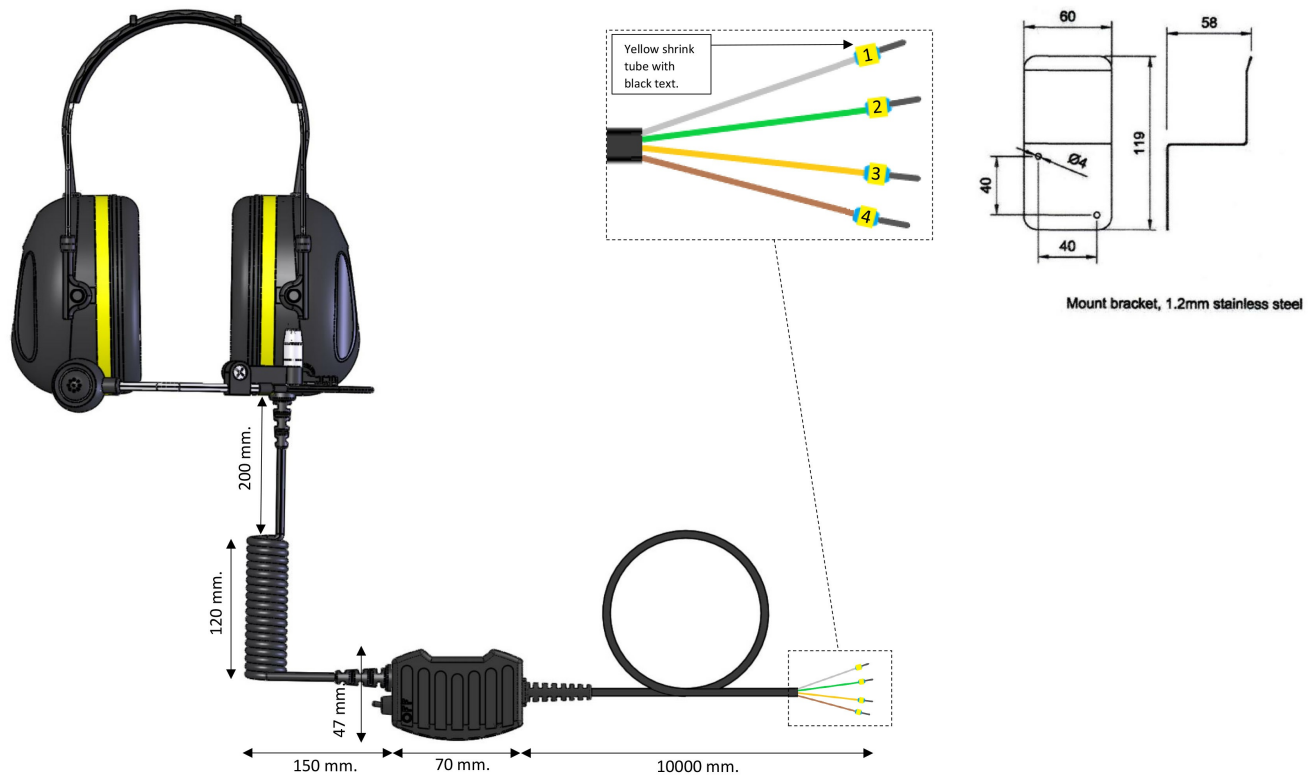

# Specifications

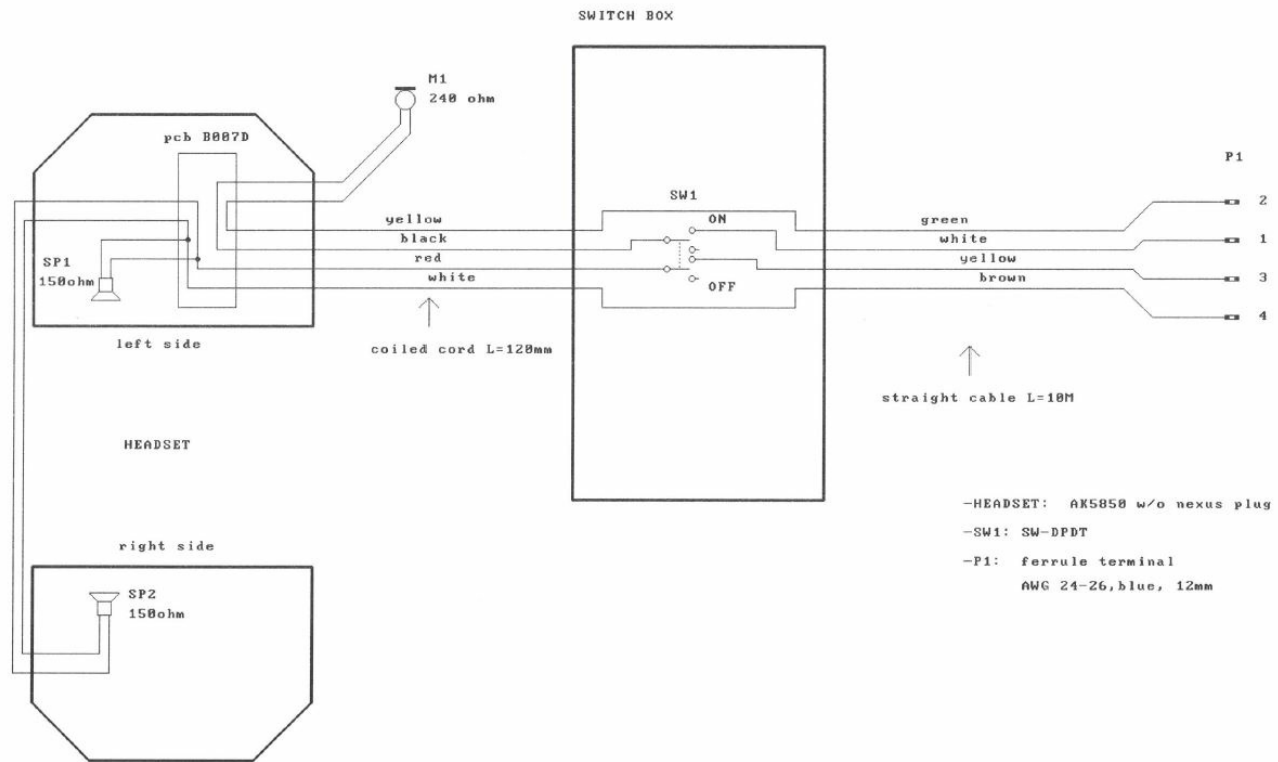

## GENERAL

Termination	Flying leads/ferrules, prepared for screw terminals
Microphone	20,5 mm. dynamic noise cancelling, 240 Ohm+- 30 %, sensitivity -57 dB+-3 dB, 0 dB=1v/pa at 1kHz, frequency response: 50Hz-6KHz.
Earphone/Speakers	27 mm. diameter, 150 Ohm+-15 %, Parallell connection, frequency response: 50Hz-10KHz.
Temperature	-40 to +60 degrees C
Storage Humidity	< 90%
Protection	IP-54 (When worn)
Attenuation rating (HML)	H=32 dB / M=28 dB / L=20
Attenuation rating (SNR)	30 dB
CE Certificate no.	12151RHS01
Dimension (HxD)	Approximately 250 x 150 mm. (adjustable).
Weight	0.4 kg
Colour	Black/Yellow
Manufacturer	Zenitel (A-kabel)
Cable	10m

## Accessories



### Hygiene kit for Headset

Hygiene kit for Headset



### Spare Boom Microphone for Headset

Spare Boom Microphone for all A-Kabel type Headsets



### Headset Stowage Bracket

Headset stowage Bracket for Wall mounting



### Spare Switchbox w/cable for VSP-36-PEL-A



### AK6070T Throat microphone for all A-kabel type Headsets

Dynamic Throat Microphone for Headset

## Used With



### VSP-211-L

Main Station - Batteryless Telephone System - 12-Way



### VSP-213-L

Main Station - Batteryless Telephone System - 12-Way



### VSP-223-L

Main Station - Batteryless Telephone System - 12-Way



### VSP-211M-L

Main Station - Batteryless Telephone System 20-Way



VSP-212M-L

Main Station Panel Mounted  
with Relay 20-Way



VSP-213M-L

Main Station - Batteryless  
Telephone System - 20-Way