

2310111120

## OC-NDC Wall Mount Bracket

Anti corrosion wall bracket for OC-NDC CCTV camera



- ✓ Wall Bracket is formed by one piece stainless steel to ensure reliable structure
- ✓ Anti-corrosion material: 316L stainless steel
- ✓ Applicable for coastal area, vessel, chemical factory, etc.

---

---

### Description

Wall mount bracket for anti-corrosion dome camera. This bracket is suitable for use with our OC-NDC 2Mp Dome CCTV Camera.

### Notes

- ✓ The bracket should be installed on the flat surface.
- ✓ The waterproof rubber is necessary for the outdoor application.
- ✓ The wall must be capable of supporting at least 3 times as much as the total weight of the camera and the bracket.
- ✓ The bracket's maximum load capacity is 3 KG (6.6 lb.).

### Technical Dimensions

**Dimension**

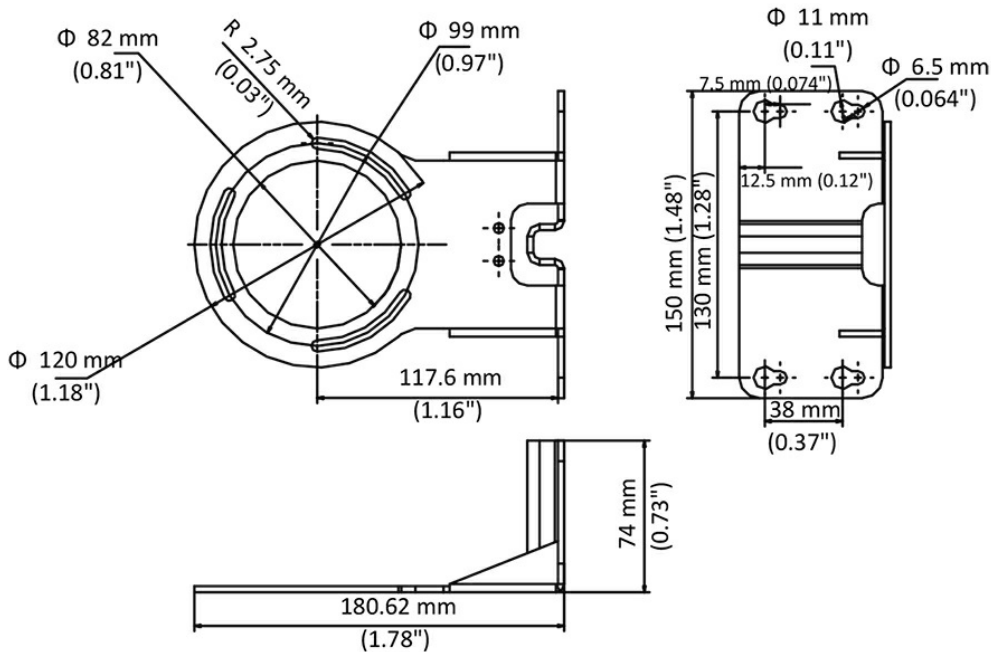

# Specifications

## DETAILS

Model:	DS-1705ZJ-DM35
Parameters:	Wall Mounting Bracket for Anti-Corrosion Dome Camera
Appearance:	Natural Stainless Steel Color
Material:	316L Stainless Steel
Dimension:	Φ 180.6 mm × 150 mm × 74 mm (1.78" × 1.48" × 0.73")
Weight:	498 g (1.1 lb.)

## Used With



### OC-NDC-2MP

Outdoor IP Dome Camera, 2MP,  
SST 316L