



2809016028

Emergency Communication Wall Unit with Turbine Cut-Out

1602 Deluxe Wall Unit Slim with Turbine Cut-Out

Note: This product is only available in North America.

Emergency points

Description

- ✓ Attention-getting LED Blue Light is included and mounted inside a polycarbonate housing. The LED Blue Light is continuously lit and flashes for duration of a call when "EMERGENCY" button is pressed to draw attention to a unit.
- ✓ Emergency Phone faceplate is illuminated at all times by an LED Panel Light
- ✓ Vandal-resistant, marine grade 316 stainless steel construction
- ✓ Designed to resist extreme weather conditions
- ✓ A variety of signage, graphics, and color choices are available
- ✓ ADA-compliant

The emergency/security wall unit is a high visibility, vandal resistant, stainless steel unit designed for use with the Zenitel Emergency/Security Stations. The Emergency/Security Wall Unit can be painted in blue, red, and yellow as required.

The wall unit is ideal for use in parking facilities, college campuses, medical centers, and multi-building complexes. The wall unit has an integrated blue light encased in Lexan. The blue light is always lit, calling attention to the location of the emergency communication unit. When the intercom station is activated, the light flashes at 78 fpm. The light flashes until either actively terminated by the personnel receiving the call or automatically upon termination of the call itself.

The wall mount is equipped with a concealed LED panel light that continuously illuminates the face of the emergency phone. The wall mount is made of a vandal resistant, 12-gauge, vertical brushed stainless steel, designed to withstand prolonged exposure to harsh environments.

Technical Dimensions

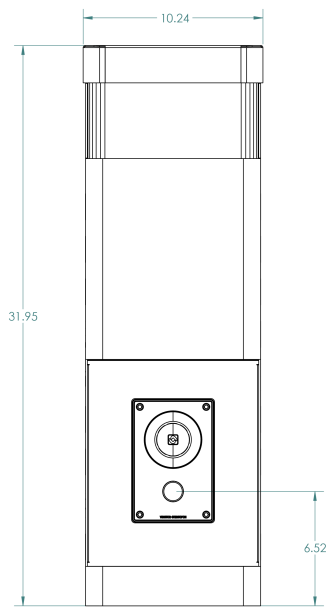

FRONT VIEW



SIDE VIEW

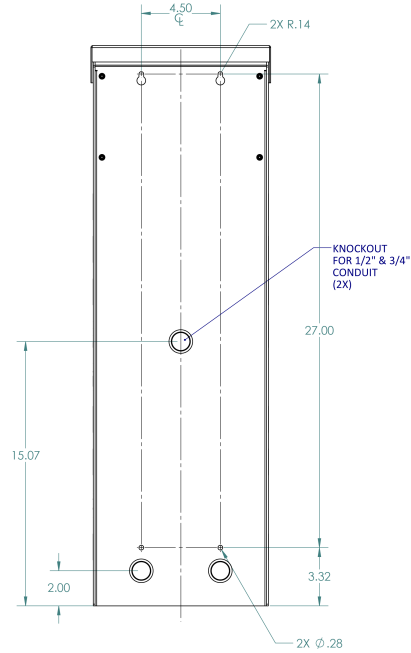

REAR VIEW

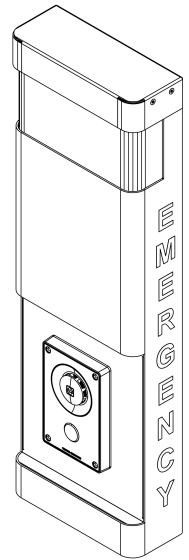

ISOMETRIC VIEW

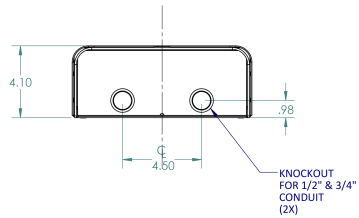

BOTTOM VIEW

Specifications

Dimensions	10 x 32 x 4 in. (253 x 810 x 101 mm)
Mount Weight	23 lbs. (10.4 kg)
Construction	Brushed marine grade (316) stainless steel with impact- and UV-resistant polycarbonate lens.
Lighting	LED Blue Light: 78 flashes per minute, 70% of initial lumens after 50,000 hours of operation. LED Panel Light: Ultra bright LEDs, 50,000 hour lifetime.
Lettering	2-inch high reflective red "EMERGENCY" lettering with wide-angle visibility is standard. Also available as "ASSISTANCE", "INFORMATION", or custom lettering, colors and graphics.
Mounting	Mounts to wall or straps to pole or kiosk. Contact Zenitel for necessary items for pole mounting.
Colors	Brushed stainless steel is standard. Available painted in custom colors
Power	LED Blue Light: 120VAC, 7.8 Watts, 35A peak inrush. LED Panel Light: 1.2 watts, 12-24 VDC/VAC, 120VAC

Used With



TCIS-2

IP and SIP Intercom



TCIS-C1

IP and SIP Intercom