



4000017652

6111**Industrial UpN intercom station**

- ✓ Weather protected unit
- ✓ Loudspeaking / handset operation
- ✓ Loudspeaker connection
- ✓ Built-in relay for external signal, max 5A
- ✓ Manual PTT (push-to-talk) key
- ✓ ACT key. (line active)
- ✓ 3 pcs direct access programmable keys. (M1-M2-M3)
- ✓ 10 pcs accessible programmable keys. (0-9)
- ✓ Volume control key (VOL) with override
- ✓ Program key. (P)

Description

6111 is a weather protected digital intercom unit with handset, and can also be used with external loudspeaker.

Technical Dimensions

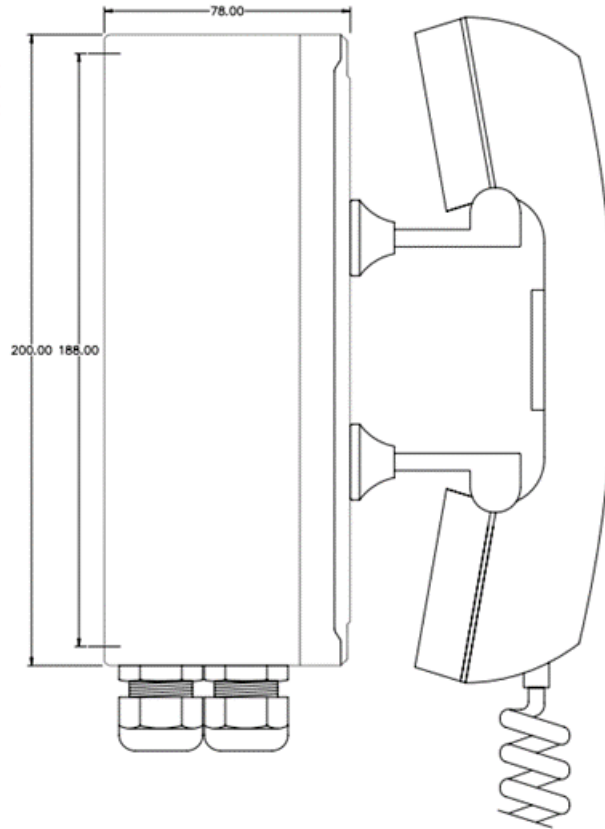
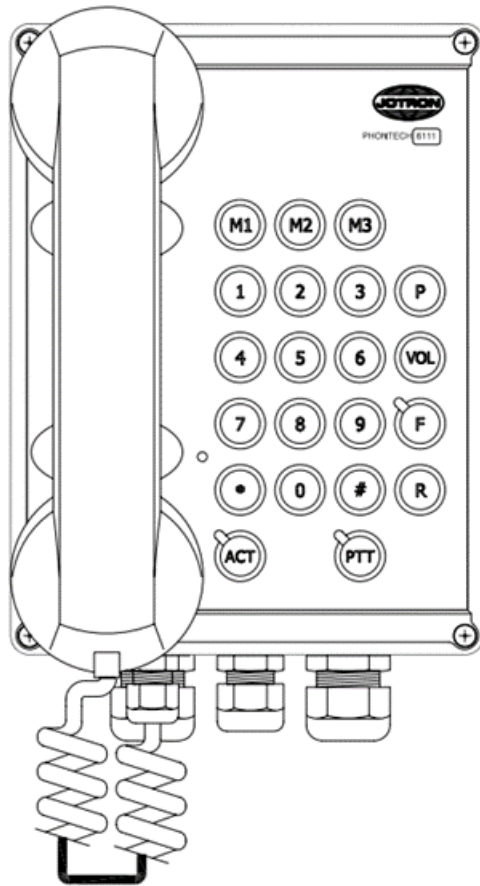
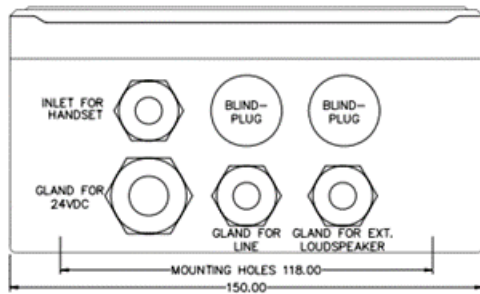

Specifications

ELECTRICAL SPECIFICATIONS:

Power supply	24VDC
Power consumption	15W (with external loudspeaker)
Termination	Screw terminals
Compass safe distance	>5m

ENVIRONMENTAL SPECIFICATIONS:

Temperature	-25°C to +55°C
Humidity	93% relative humidity (at +40°C)
Ingress protection	IP56

MECHANICAL SPECIFICATIONS:

Dimension (WxHxD)	150x200x154mm
Weight	1.2kg
Material	ABS
Colour	RAL 7035
Mounting	To wall
Fixing	4 pcs M4 bolts
Access	Front
Cable entry	Bottom
Gland type	PG-7, 9 & 13,5

COMPLIANCY:

Complies to IEC 60945
Marine equipment