

1020600943

VSP-223-L

Main Station - Batteryless Telephone System - 12-Way



- ✓ 12 extensions selector switch
- ✓ Built-in relay latch timer for activation of external visible or audible 24V DC signal units
- ✓ Alarm stop button
- ✓ Noise compensated microphone
- ✓ Optical LED call indication at front (in addition to audible call signal)
- ✓ Flush mounted
- ✓ Wall mounting with corresponding metal cabinet type MBOKS-G
- ✓ Desk mounting with corresponding wooden cabinet type VSPO-OAK
- ✓ Suitable for installation in control rooms and noisy areas like steering gear, engine- and thrusterrooms, etc

Description

VSP-223-L Main Station: Noise Cancelling Batteryless Telephone

The VSP-223-L Main Station enhances our 12-Way Batteryless Telephone System with features tailored for noisy areas.

Features includes:

- ✓ Versatile Installation Options: Flush-mount, wall, or desk for optimal placement.
- ✓ External Signal Activation: Built-in relay latch timer for activating external alarms, improving safety alerts.
- ✓ Noise-Compensated Microphone: Ensures clarity in communication in areas like engine rooms.

The VSP-223-L is suitable for installation in control rooms and noisy areas like the steering gear, engine- and thruster rooms, etc, ensuring clear uninterrupted communication even in critical situations such as full blackout of the vessels power.

Technical Dimensions

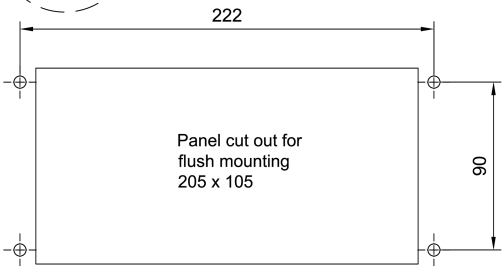
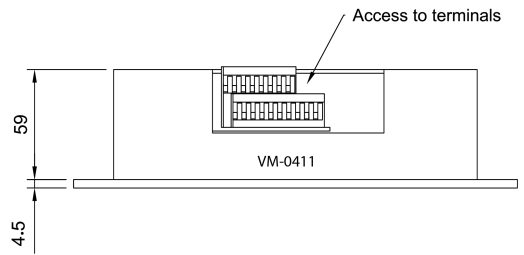
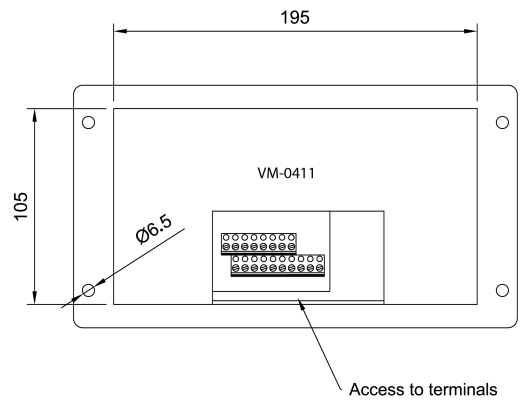
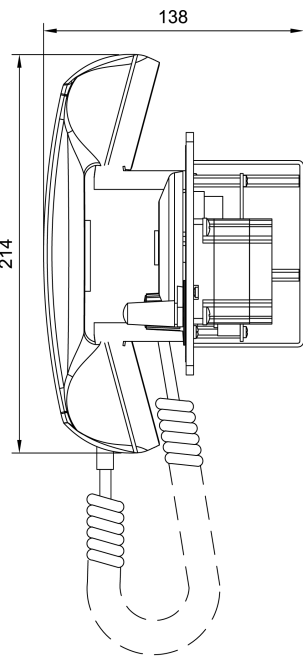
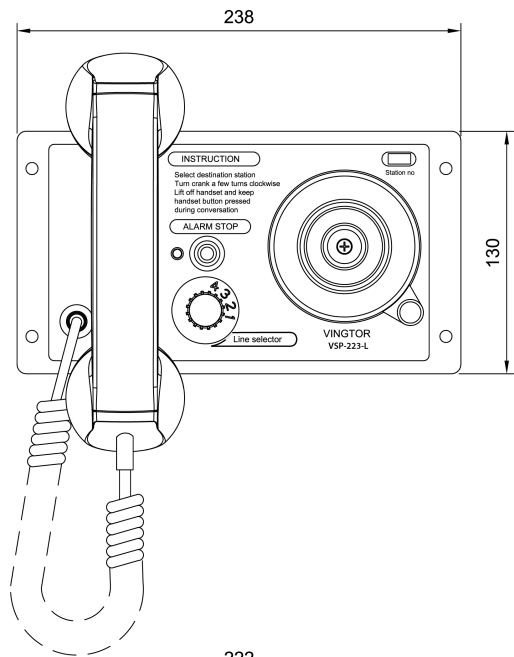

Note: VM-0411 Protection Cover is an optional accessory

Specifications

GENERAL

Connections	Screw terminals
Color	Black
IP rating	IP-44
Dimensions (WxHxD)	238 x 130 x 77 mm
Panel cut-out	205 x 105 mm
Weight	1.30 kg
Operating temperature range	-25°C to 55°C
Switching Current (max)	4 A
Compass Safe Distance	> 155cm

Accessories



VM-0411

Protection cover for VSP-stations



MBOKS-G

VSP Batteryless Telephone System



VSPC-OAK

Wooden OAK Cabinet



VSP-36-PEL-A

Headset with boom mic, headband, and 10m cable



VSP-36-PEL-A/20

Headset with boom mic, headband, and 20m cable



CD-4

Plugbox Waterproof



VSP-36-PELP-A

Headset with boom mic, headband, and 10m cable



VSP-36-PELP-A/20

Headset with boom mic, headband, and 20m cable



VSP-36-PELP-A/25

Headset with boom mic, headband, and 25m cable



IRR-24

Relay Box



IRR-VSP-220

Relay box 220V AC for VSP-12 way