

3006200025

VSP-211M-L

Main Station - Batteryless Telephone System 20-Way



- ✓ 20 extension system
- ✓ 2 positions group selector switch
- ✓ 10 extension line selector switch
- ✓ Built-in system amplifier w/ capacitor battery
- ✓ Has terminals for auxiliary 24V DC when used as Common Battery Telephones.
- ✓ To avoid noise problems, the 24V DC must be supplied via a DC/DC converter
- ✓ LED call indication in front
- ✓ Flush mounted
- ✓ Wall mounting with corresponding metal cabinet type MBOKS-G
- ✓ Desk mounting with corresponding wooden cabinet type VSPC-OAK
- ✓ Suitable for installation in wheelhouse and control room

Description

VSP-211M-L Main Station: 20-Way Batteryless Telephone System

The VSP-211M-L Main Station offers a dependable solution as part of our established 20-Way Batteryless Telephone System. This system is designed to ensure seamless communication onboard vessels, even during power outages, making it a vital component of any ship's safety and communication equipment. Key features include:

- ✓ Flush-Mounting Design: For straightforward installation in various locations onboard.
- ✓ Selective Calling: Enhanced with a 10-position selector switch and a 2-position group selector for efficient communication between stations.
- ✓ Built-In System Amplifier: Uses a capacitor battery to maintain functionality without external power sources.

The VSP-211M-L is a proven choice for vessels requiring a robust and reliable secondary communication system in line with SOLAS standards.

Technical Dimensions

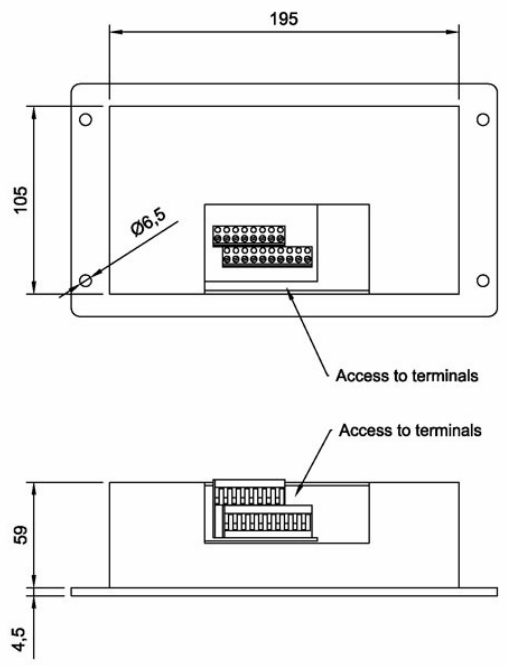
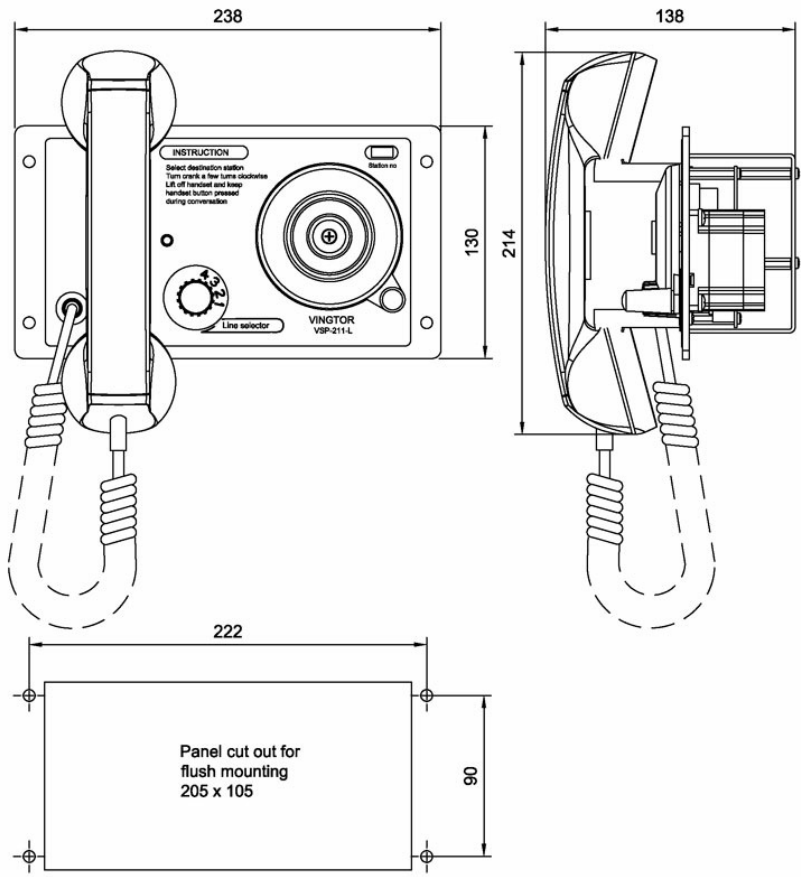

Specifications

GENERAL

Connections	Screw terminals
Color	Black
IP rating	IP-44
Dimensions	238 x 205 x 137 mm (w/ handset and built-in depth)
Panel cut-out	205 x 105 mm
Weight	1.30 kg
Operating temperature range	-25°C to 55°C
Compass Safe Distance	> 155cm

Accessories



MBOKS-G

VSP Batteryless Telephone System



VSPC-OAK

Wooden OAK Cabinet



VSP-36-PEL-A

Headset with boom mic, headband,
and 10m cable



VSP-36-PEL-A/20

Headset with boom mic, headband,
and 20m cable



CD-4

Plugbox Waterproof



VSP-36-PELP-A

Headset with boom mic, headband,
and 10m cable



VSP-36-PELP-A/20

Headset with boom mic, headband,
and 20m cable



VSP-36-PELP-A/25

Headset with boom mic, headband,
and 25m cable



IRR-VSPM-24

Relay box 24V DC for VSP M



IRR-VSPM-220

Relay Box 220V AC for 20 Way system