

3006200042

## VSP-5012

### EX Buffer Unit



- ✓ Intrinsically safe buffer unit for mounting in safe area
- ✓ Supports up to 4 Ex(i) telephones - VSP-512
- ✓ 4x 24V DC outputs to Ex signal units
- ✓ 12 call signal outputs to safe area
- ✓ Delivered in a painted steel cabinet for wall mounting
- ✓ Can be delivered with up to 2x zener barriers for 24V DC I.S. sounder in zone 0
- ✓ (½ x zener barrier for each sounder)



## Description

Ensures uninterrupted communication between Ex- and safe zone in a Batteryless telephone system (VSP). To be mounted in Safe area with Barriers into the Hazardous (Ex) area. It accommodates up to 12 Batteryless telephones within the system, enabling seamless communication. Call signals are distributed in the Hazardous area via EX(d) signal units controlled by relay outputs. Encased in a durable painted steel cabinet designed for wall mounting. It offers optional integration with up to 2 zener barriers (4 extension numbers) for 24V DC sounders in zone 0, guaranteeing reliable operation and enhanced safety in hazardous environments.

## Technical Dimensions

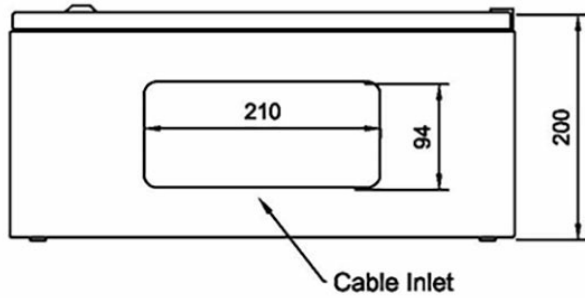
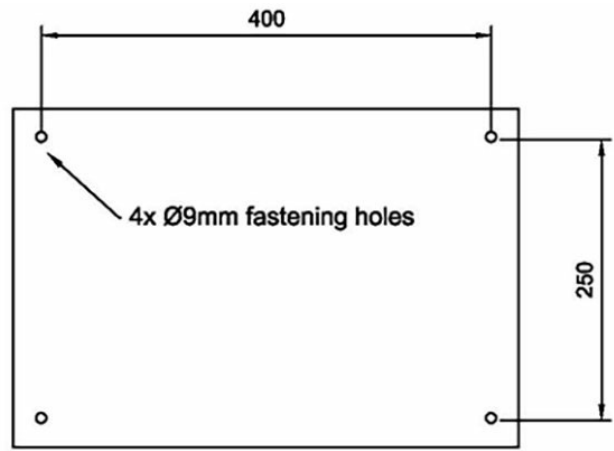
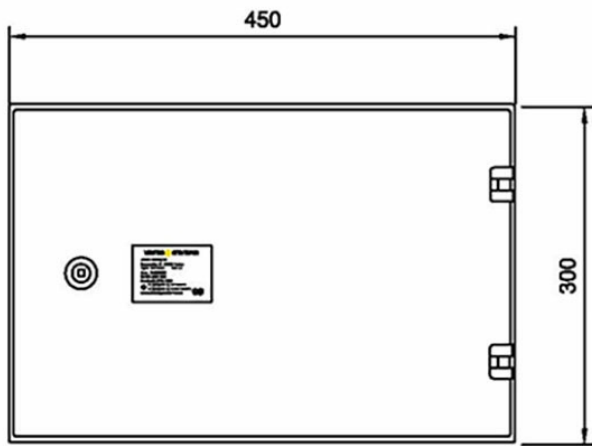

 ATEX Approved product
Certification body <b>Nemko</b>
Certificate no. <b>Nemko: 05 ATEX 1059</b>
Protection system <b>II (1)G [EEx ia] IIC Ta: 60°C</b>

# Specifications

## GENERAL

Dimensions (WxHxD)	450 x 300 x 200 mm
Mounting	Wall mounted
Weight	11.0 kg
Housing	Steel cabinet
Color	Beige / RAL 7032
Cable entry	Pre-cut cable inlet in bottom
Connections	Screw terminals
Operation voltage	24V DC
Power Consumption	24W (max)
Protection mode	Ex II (1) G EEx ia IIC T6
Certificate	Presafe 15 ATEX 6475 / IECEX PRE 15.0024
IP-rating	IP-44

ORDER NUMBER	DESCRIPTION	SHIP WEIGHT
3006200042	VSP-5012 buffer unit with capacity to call 12 main stations in safe area	
Related items:		
3006200044	VSP-512 Telephone I/S wall W/12-pos switch IP44, EEX ia IIC T6. VSP-512-PEL Intrinsically safe headset for connection to VSP-512 w. On/off switch box,Beltclip and 10 m cable.	
3006102010	Ex approv. light 24V DC WT - IP-66, incl. 1 x cable gland, Ex li 2 G - EEx D Ilc T5	
3006102015	Ex appr. light 220v AC WT - IP-66, incl. 1x cable gland, Ex II 2 G - EEx D Ilc T5	
DHW2-24	Ex signal bell 24DC WT - IP-66 -II 2 G EEx de Ilc T6	
DHW1	Ex signal bell 230 VAC WT - IP-66 -II 2 G EEx DE Ilc T6	
DHH1-230	Ex signal horn 230VAC 50/60 Hz WT - IP-66 -II 2 G EEx DE Ilc T6	
1020600992	Relay box for 230V AC Safe area	

## Used With



### VSP-512

Intrinsically Safe Operating Unit