

2810010125

WCAB-1005-V2

Wall cabinet 316L SST 300x380x210mm w/brackets



- ✓ Stainless steel 1.4404(AISI 316L)
- ✓ With mounting plate
- ✓ Wall mounting set for outside mounting to wall
- ✓ Single cam lock (3 mm double-bit lock)
- ✓ IP-66



Description

The WCAB-1005-V2 is a robust and versatile SST wall-mounted cabinet designed for various applications.

This enclosure is made from high-quality stainless steel 1.4404 (AISI 316L), ensuring durability and resistance to corrosion. The design features a brushed surface finish with a grain size of 400, offering an aesthetic appeal while maintaining a high level of protection.

It includes a single door with a 130° opening angle and a foamed-in PU seal, enhancing its protective capabilities. The door is equipped with a cam lock and the enclosure comes with a zinc-plated mounting plate.

This enclosure is suitable for a wide range of industries due to its IP 66 protection rating, ensuring it is dust-tight and protected against powerful water jets.

Technical Dimensions

FRONT VIEW

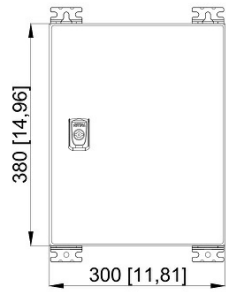

REAR VIEW

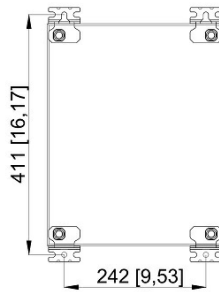

RIGHT VIEW

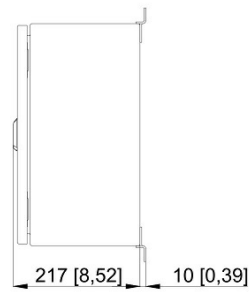

LEFT VIEW



TOP VIEW

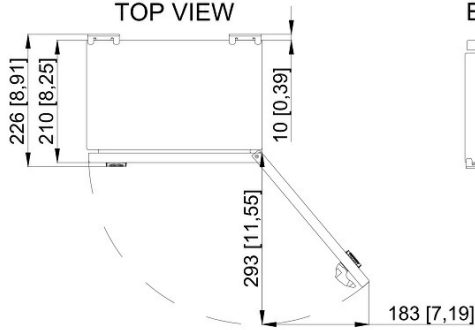

BOTTOM VIEW

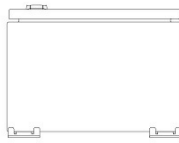

CABINET TECHNICAL DATA

Model:	Rittal AX 1302.000
Material:	Stainless steel 1.4404 (AISI 316L)
IP Grade:	IP-66
Weight:	8,9kg (19,62lbs)
Lock:	Double bit lock
Dimensions:	300x380x210mm (WHD)
Item Numbers:	2810010125 - WCAB-1005-V2 1153901103 - WCAB-1005M-V2
Max. door opening angle:	130°

Specifications

GENERAL

Dimensions (WxHxD)	300x380x210mm
Weight	8,9kg (19,62lbs)
Additional mounting plate:	Dimension 250x355mm
Material	Enclosure: Stainless steel Door: Stainless steel, all-round foamed-in PU seal
Door opening angle	130°