

## EN54 ROUND FRAMELESS CEILING SPEAKER

- 6W 100V LOUDSPEAKER
- SIZE 6.5" (165 MM)
- QUICK MOUNT
- WAGO 221 CONNECTORS
- WEATHERPROOF TO IP21C
- EXCELLENT SOUND QUALITY
- FULLY CERTIFIED TO EN54-24



### OVERVIEW

The SPCR-06W-65-EN54 is a 6W 100V round frameless ceiling mount loudspeaker, which has a 6.5" (165mm) full-range chassis providing excellent sound quality with speech and background music, and which is certified to EN54-24. The speaker is fitted with a 100V transformer which has three power adjustment tapings of 6W, 3W, and 1.5W.

The SPCR-06W-65-EN54 has a powder coated metal chassis and grille, with the high quality finish giving good long-term protection and resistance to corrosion. The speaker is supplied with a rear fire dome, and its enclosure is ingress protection rated to IP21C. As standard the speaker is coloured to match RAL9016 'Traffic White', however the speakers can be supplied in any four-digit RAL or NCS colour, as a special order.

Quick connections using the WAGO 221 connectors and easy ceiling mounting is provided through the use of spring clamps, for use with a possible ceiling thickness of between 1mm and 45mm. The 100V loudspeaker line cabling is fed through rubber grommets in the fire dome and is connected to the speaker by means of the WAGO 221 connectors. For additional reliability the speaker chassis is damp-resistant.

Please note that although very thin ceilings can be used as a mounting surface, it should be ensured that the ceiling thickness and strength are appropriate to the weight of the speaker, and to the thickness and weight of the 100V line cable.

The loudspeaker is optionally available with a DC blocking capacitor fitted, providing compatibility with DC loudspeaker line monitoring systems. The part number for this DC monitoring compatible version is SPCR-06W-65-EN54-DC.

EASE data is available for this speaker on request.

**PRODUCT ATTRIBUTES**

Power Tappings	6W / 3W / 1.5W
Impedance	1667 / 3333 / 6667 ohm
Frequency Range	63 - 16,000 Hz
Frequency Response	56 - 18,000 Hz
SPL 1W / 1m, peak	97.0 dB
SPL 1W / 4m, peak	85.0 dB
SPL Pmax / 4m, peak	92.0 dB
Sensitivity EN54-24, 1W / 4m	80.0 dB
Sensitivity IEC 268-5, 1W/1m	92.0 dB
Dispersion (-6dB, 500Hz)	180°
Dispersion (-6dB, 1KHz)	180°
Dispersion (-6dB, 2KHz)	128°
Dispersion (-6dB, 4KHz)	94°
Temperature Range	-20 / +80 °C
Dimensions	220 x 104mm
Weight (net)	1.00 kg
Colour	RAL9016 'Traffic White'
Connector	WAGO 221 connector
Mounting	Quick Fit Mounting
IP Rating	IP21
Packing Unit	12
Maximum cable cross section	4mm <sup>2</sup>
Maximum cable cross section loop	4mm <sup>2</sup>

POLAR DIAGRAM

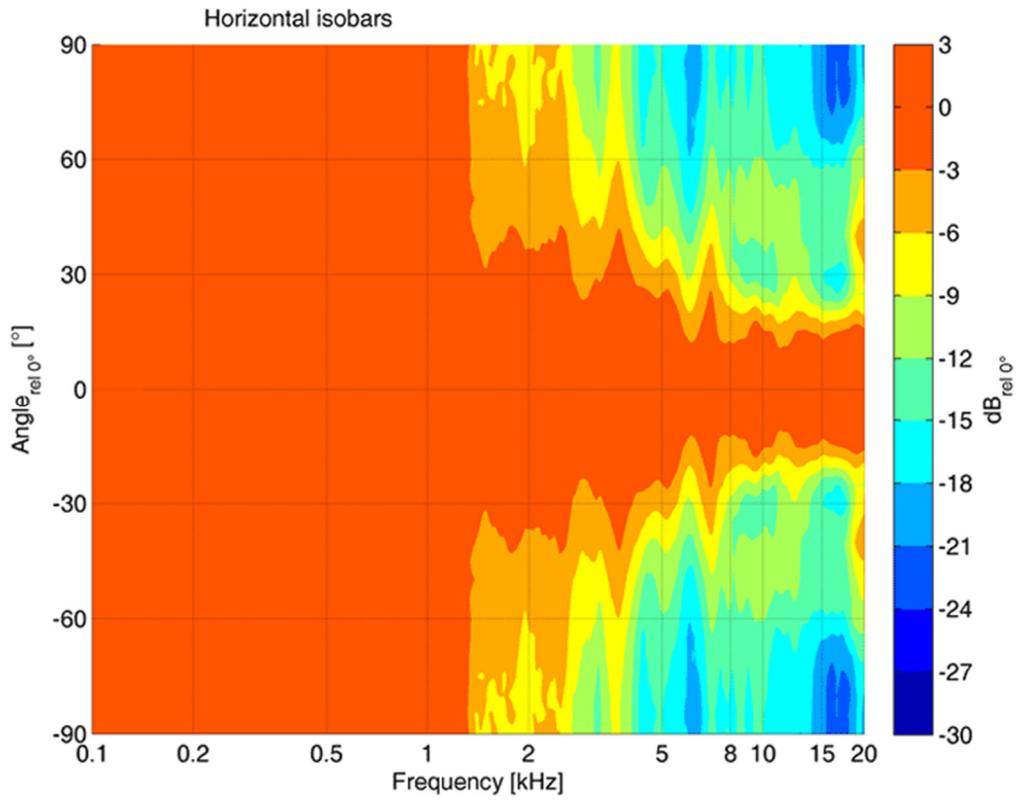

FREQUENCY RESPONSE DIAGRAM

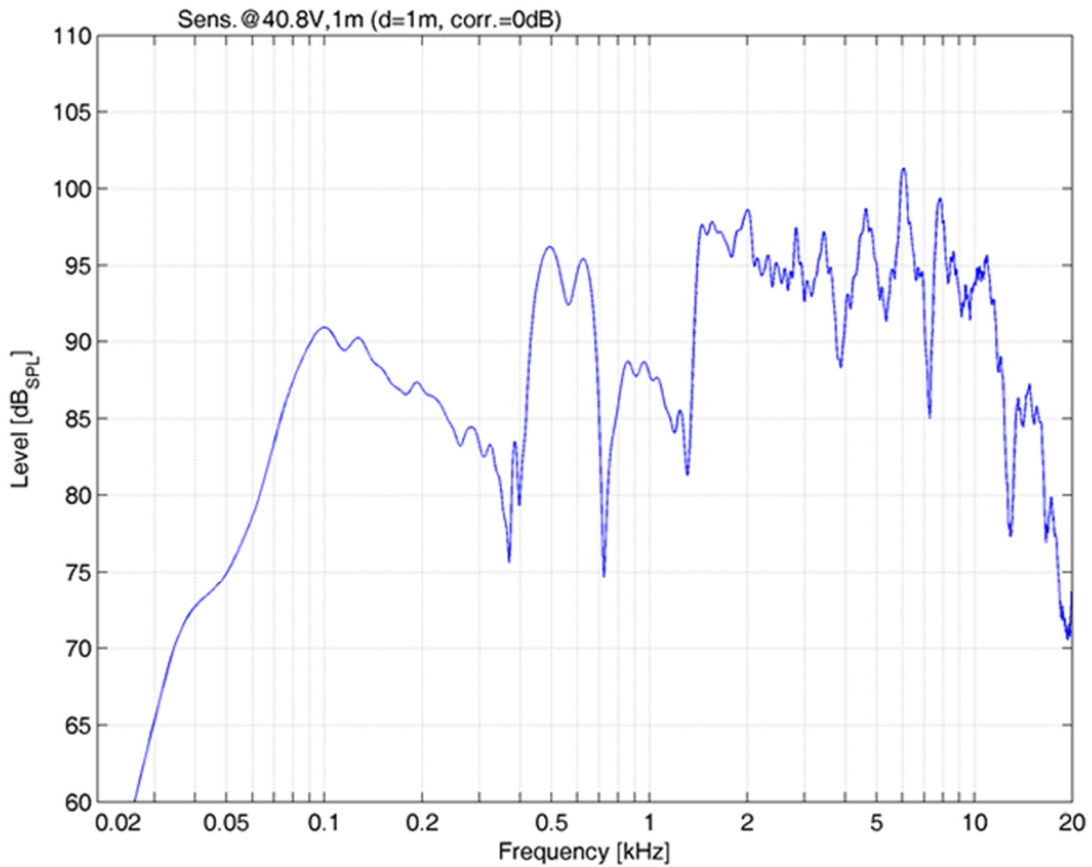

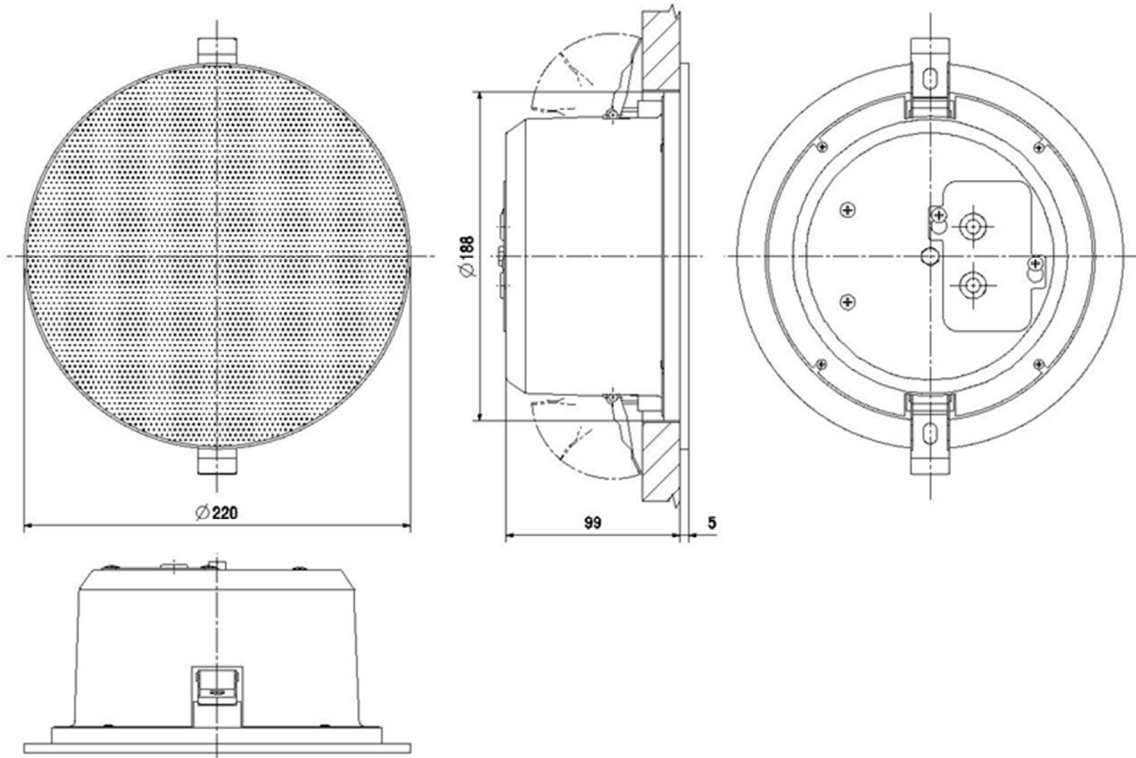
**DIMENSIONAL DIAGRAM**

Measurements according to DIN IEC 268-5  
 RoHS compliant (2011/65/EU & 2015/863/EU)



This equipment is designed and manufactured to conform to the following EU Directives:  
 Low Voltage: 2014/35/EU  
 Restriction of Hazardous Substances (RoHS): 2011/65/EU & 2015/863/EU

**Manufacturer**

Application Solutions (Safety and Security) Limited  
 Unit 17 - Cliffe Industrial Estate - Lewes - East Sussex - BN8 6JL - U.K.  
 Tel: +44(0)1273 405411

[www.asl-control.co.uk](http://www.asl-control.co.uk)

All rights reserved.

Information contained in this document is believed to be accurate, however no representation or warranty is given and Application Solutions (Safety and Security) Limited assumes no liability with respect to the accuracy of such information.



Assessed to ISO 9001  
 LPCB Cert No: C1043